

Emergency Aid Camp Infrastructure



Osprey 452

4" x 4" General Purpose Self Priming Centrifugal Pump with Lombardini 9LD625 Diesel Engine

Applications include:

Heavy Duty Dewatering (Fresh & Seawater), Chemical Handling, Potable Water Supply



Pump:

Centrifugal self-priming pump in cast iron construction with integral non-return valve, semi open clog resistant impeller, carbon/ceramic mechanical seal, renewable wear plate/volute and screwed BSP male suction and discharge connections.

Engine:

Lombardini 9LD625 - 2 two cylinder 4 stroke air cooled diesel engine developing 16.9 kW at a nominal 2700 rpm complete with handle start, 10 litre (3 hrs. running) fuel tank, throttle control, oil bath air-cleaner, replaceable element fuel and oil filters and exhaust silencer.

Solids handling capability: Up to 26mm Ø

Standard Options:

- A. Individual plywood case packing.
- B. Pump spares for 1000 hours normal operation.
- C. Engine spares for 1000 hours normal operation.
- D. Hose kit GPSP4/620 comprising 6 m length of suction hose, 20 m length of delivery hose, push-on strainer/footvalve, female BSP hose couplings and 3 hoseclips.
- F. 4 wheel site trolley.
- G. 2 wheel road going trailer.
- H. Recoil operated spring start.
- I. 12 volt keytype electric start with lead acid battery pack.

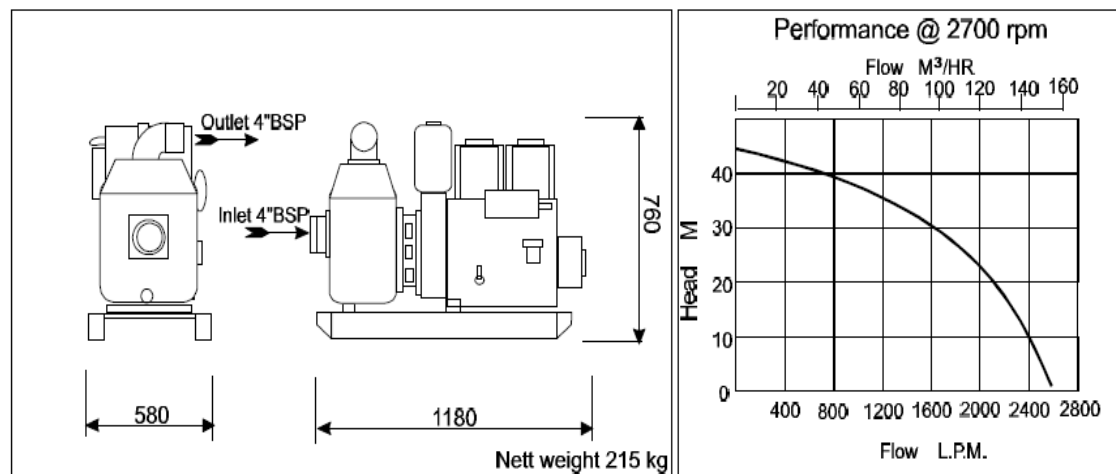

Butyl Products Ltd.

Lingfield House, 11 Radford Crescent, Billericay, Essex,
CM12 0DW, United Kingdom. T: +44 (0) 1277 653 281

F: +44 (0) 1277 657 921 E: enquiries@butylproducts.co.uk

W: butylproducts.co.uk

