

# Emergency Aid Camp Infrastructure



## Fulmar 664WES

### 6" x 6" General Purpose Self Priming Centrifugal Pump with Lombardini LDW2204 Diesel Engine

Applications include:

Heavy Duty Dewatering (fresh & seawater) - Chemical Handling - Potable Water Supply



- Robust cast iron construction
- Pump and Engine are flexibly coupled for easy maintenance
- Fabricated steel baseplate with fixing holes
- Solids handling to 63 mm Ø
- Integral non return valve
- Renewable wear plates
- Self Priming to 7 m
- Long life Tungsten Carbide/Tungsten Carbide mechanical seal
- 150 mm PN16 flange connections
- Single point lift frame

Powered by a Lombardini high quality industrial water cooled four cylinder diesel engine model LDW2204, developing 22 kW at a nominal 1600 rpm complete with 12 volt electric key start/stop, battery, 6 hour fuel tank, throttle control, engine protection for LOP/HW, dry type replaceable element, air, oil and fuel filters.

Engine is enclosed in an acoustic weatherproof canopy designed to reduce noise levels to 70 dBA at 7 metres.

Set is supplied with Pump and Engine Operating and Instruction Manuals

#### Standard Options:

- |   |                    |
|---|--------------------|
| A. Individual plywood case packing.               | E. Quick couplings |
| B. Pump spares for 1000 hours normal operation.   | F. Road trailer    |
| C. Engine spares for 1000 hours normal operation. | G. Welding collars |
| D. Hose kit                                       |                    |

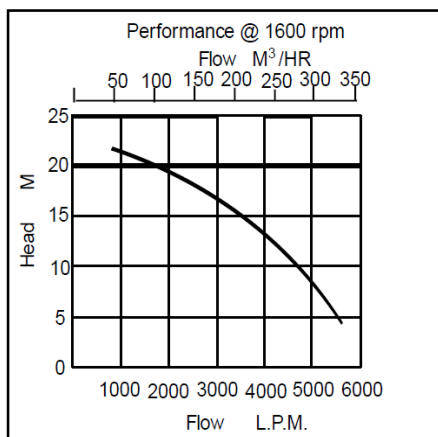
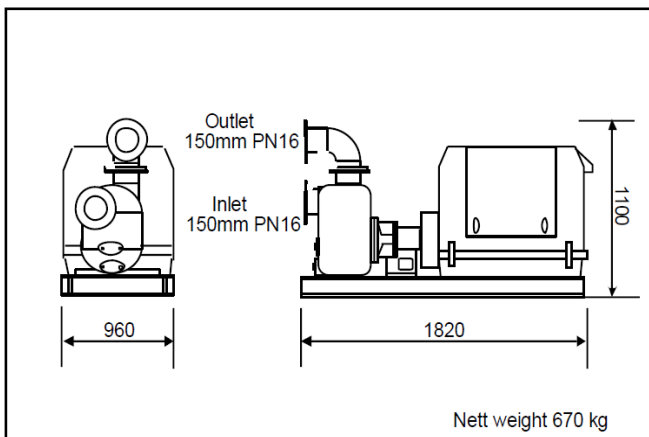

#### Butyl Products Ltd.

Lingfield House, 11 Radford Crescent, Billericay, Essex,  
CM12 0DW, United Kingdom. T: +44 (0) 1277 653 281

F: +44 (0) 1277 657 921 E: [enquiries@butylproducts.co.uk](mailto:enquiries@butylproducts.co.uk)

W: [butylproducts.co.uk](http://butylproducts.co.uk)