

Emergency Aid Camp Infrastructure



Merlin 251

2" x 2" General Purpose Self Priming Centrifugal Pump with Lombardini 15LD225 Diesel Engine

Applications include:

Dewatering (fresh & seawater) – Chemical Handling – Potable Water Supply



Pump:

Centrifugal self-priming (to 7m) pump in cast iron construction with integral non-return valve, semi open clog resistant impeller, carbon/ceramic mechanical seal, steel roll-over frame with anti vibration mounts and screwed BSP male suction and discharge connections.

Engine:

Powered by a Lombardini lightweight industrial air cooled single cylinder diesel engine model 15LD225 developing 3.5 kW at a nominal 3600 rpm complete with recoil start (optional electric), 3 litre 3 hr. fuel tank, silencer, throttle, dry type air, oil and fuel filters. Set is supplied with Pump and Engine Operating and Instruction Manuals.

Solids handling capability: Up to 12mm Ø

Standard Options:

- A. Individual plywood case packing.
- B. Pump spares for 1000 hours normal operation.
- C. Engine spares for 1000 hours normal operation.
- D. Hose kit
- E. 2 wheel site trolley

Other options available upon request.

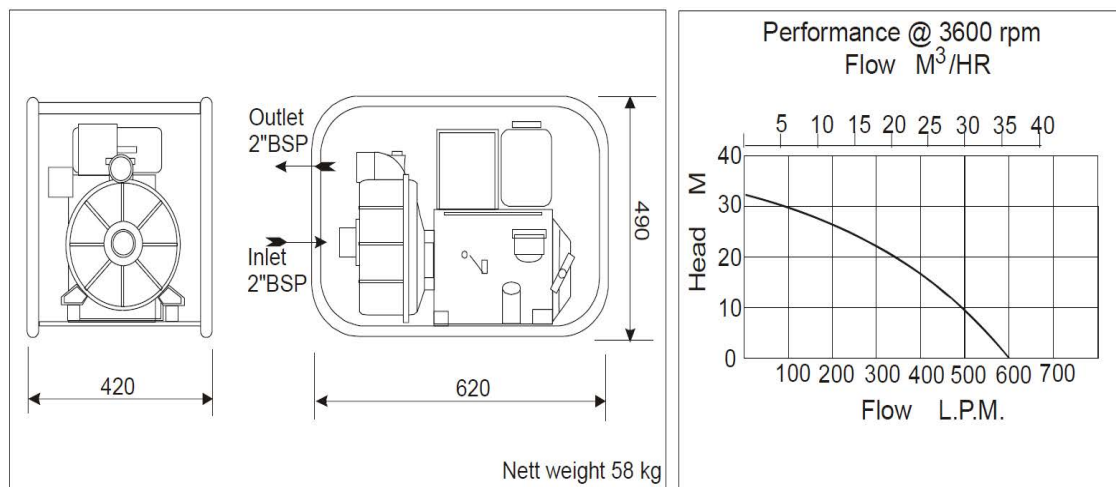

Butyl Products Ltd.

Lingfield House, 11 Radford Crescent, Billericay, Essex,
CM12 0DW, United Kingdom. T: +44 (0) 1277 653 281

F: +44 (0) 1277 657 921 E: enquiries@butylproducts.co.uk

W: butylproducts.co.uk