

Emergency Aid Camp Infrastructure



Merlin 351

3" x 3" General Purpose Self Priming Centrifugal Pump with Lombardini 15LD350 Diesel Engine

Applications include:

Dewatering (fresh & seawater) - Chemical Handling - Potable Water Supply



- Robust Cast Iron Construction
- Rigid Monobloc Design
- Fabricated Steel Baseplate with Fixing Holes
- Solids Handling to 18 mm \emptyset
- Integral Non Return Valve
- Self Priming to 7 m
- Silicone Carbon/Ceramic Mech. Seal
- Stainless Steel Shaft Sleeve
- Screwed BSP Male Connections

Powered by a Lombardini lightweight industrial air cooled single cylinder diesel engine model 15LD350, developing 4.5 kW at a nominal 3600 rpm complete with recoil start (optional electric start), 4.3 litre 4 hour fuel tank, silencer, throttle, dry type air, oil & fuel filters. Set is supplied with Pump and Engine Operating and Instruction Manuals

Standard Options:

- A. Individual plywood case packing.
- B. Pump spares for 1000 hours normal operation.
- C. Engine spares for 1000 hours normal operation.
- D. Hose kit
- E. Site trolley
- F. Quick couplings
- G. Electric start

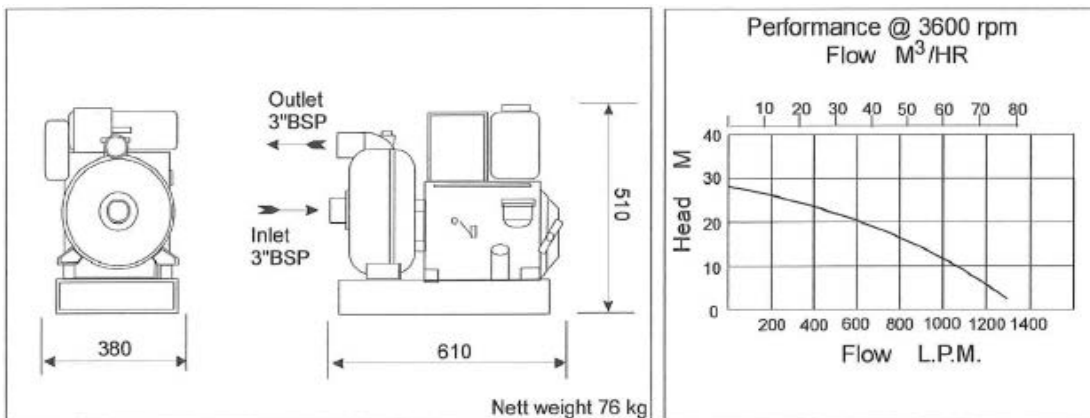

Butyl Products Ltd.

Lingfield House, 11 Radford Crescent, Billericay, Essex,
CM12 0DW, United Kingdom. T: +44 (0) 1277 653 281

F: +44 (0) 1277 657 921 E: enquiries@butylproducts.co.uk

W: butylproducts.co.uk